

ALWI-551



Alkaline Water Ionizer

Healthy life comes from nice water! Water is Vital to Life!





■ Important safety instructions

Before enabling Read all instructions:

Danger 1 In order to avoid electric shock:

1. Please pull the plug out of the power socket immediately after use.
2. Do not use in the shower.
3. Do not place or keep in the bath or the edge of the sink, and accidentally fall into the water.
4. Do not place or fall into water or other liquids.
5. Do not touch when falling into the water, please unplug the power cord immediately.

Warning 1 to avoid fire, electric shock, fire or injury

1. After plugging in the power plug, do not leave the unit.
2. Children or persons with disabilities need to be properly supervised when using or being on the side.
3. This machine should be used for the original purpose described in this manual. Do not use the accessories of this machine for the purpose recommended by the manufacturer.
4. When the cable or plug of the unit is damaged or malfunctions, when the unit falls or is damaged or falls into the water, do not operate the unit. Please hand it to the machine station for inspection or repair.
5. The cable of this unit is often kept away from the hot surface.
6. Do not use this unit when sleeping or not awake.
7. Never push foreign objects into any holes or tubes in the unit.
8. Do not use outside the house, in any spray or oxygen controlled space.
9. Please connect the ground wire. Please refer to the grounding method.

■ Grounding instructions

This machine needs to be grounded. In the event of an electrical short circuit, the grounding wire allows current to flow to the ground through the grounding wire, which can reduce the risk of electric shock.

This unit is equipped with a grounding wire with a grounding plug. The plug should be plugged into a properly grounded outlet.

DANGER—Improper use of a grounded plug can create a risk of electric shock.

Do not connect flat leaf terminals when grounding wires or plugs need to be repaired or replaced. The green wire that is not insulated with yellow stripes and is insulated from the outside is the ground wire.

If the grounding instructions do not fully understand or do not know if the unit is properly grounded, contact a qualified electrician or service personnel.

For other grounded, patched products: This machine has been equipped with a standard wire at the factory to be connected to a regular circuit.

Check if the unit is connected to the same size as the plug. Do not modify the supplied plug. If your plug does not fit into the outlet, have a qualified electrician set up the appropriate outlet.

If the unit is wired for re-wiring for use on circuits of other specifications, it should be performed by qualified service personnel.

www.freecoolsystems.com

Additional cable: An additional (extended, etc.) cable is required. Use only a three-wire (extended) wire with three blade grounding plugs and plug into a socket that accepts the plug. Replace or repair the damaged cable.



Catalog

■ Safety sign description	4
■ Beauty water · strong acid water · preparation for use of alkaline water	5
■ Feature	6
■ Annex	7
■ The name of each part	8
■ Control panel	10
1 Preparation work	11
• Switching faucet installation method with nozzle	12
• Setting device	13
• About power line wiring	14
2 Methods of use	15
• Volume adjustment	16
• Method for generating alkaline water	17
• Beauty water production method	19
• Method for generating strong acidic water/strongly alkaline water	20
• Method of generating purified water	23
• Automatic cleaning	24
3 Replacement filter	25
4 Safety instructions	27
• Cleaning with citric acid	29
5 Solve the problem	30
6 Optional	31
7 Parameters Table	32



Safety sign description

Base of risk



Caveat

If you do not follow the instructions in this manual, there may be an emergency hazard related to human life.









Notice

Failure to follow the instructions described in this manual may result in minor or even serious injury to humans.

- * The precautions indicated here are divided into [△Warning] [△Caution] If there is a serious result of death or serious injury when misused, The column [△Warning] is listed in the summary. However, the items in the [△Note] column may cause serious results depending on the situation. Please be sure to follow the above important safety related content.
- * Manufacturers are not responsible for product failures or accidents when using or not following the contents of this manual. Please understand.
- * After reading this book, be sure to keep it in a safe place for future reference.

Description of the sign

Mark	Theme	Meaning
	General	Used to advertise unspecified general attention, warnings, and dangers.
	General	Used to advertise unspecified general prohibitions.
	General	Used to indicate the behavior of a general user.
	No open flames	Used to warn that under certain conditions, close to open flames may cause the product to catch fire.
	It is forbidden to use water facilities such as bathhouses and showers.	In places such as baths, showers, etc. where water is easily accessible, the unit is not waterproof.
	Disassembly is prohibited	Used to warn against self-repair or disassembly, so as to avoid possible electric shock and injury.
	Plug out the plug from the socket	Used to indicate a fault or when it is possible to mine, instruct the user to unplug the plug from the outlet.



■ Preparation for use of beauty water, strong acid water, and alkaline water



Warning — For safety and compliance —

 Must comply	<ul style="list-style-type: none">• Be sure to consult a doctor when using beauty water or strong acid water in the following cases.<ul style="list-style-type: none">■ Skin delicate■ Allergic constitution• When you feel allergic skin after using beauty water, please stop using it and consult a doctor.• Please pay attention to the following matters when drinking alkaline (reduced) water.<ul style="list-style-type: none">■ Do not take medicine with alkaline (reduced) water.■ Do not drink alkaline (reduced) water if you have kidney disease such as renal insufficiency or potassium excretion disorder.■ When you feel uncomfortable after drinking, stop using it and follow the doctor's advice.■ If you are sick, please follow the doctor's advice before drinking.■ Prepare baby medicines, baby foods, and do not use alkaline (reduced) water.
---	--

Notice

 Prohibited	<ul style="list-style-type: none">• Do not drink the following waters: it may damage your health.<ul style="list-style-type: none">■ Strong acid water■ Water in beauty■ Water washing■ Water containing pH (pH) solution■ Strong alkaline (reduced) water when strong acidic water is formed■ Water discharged from the drain• When drinking alkaline (reduced water), please adjust the pH (pH) to 9.5 or less. We hope that you will not drink water with a pH value (pH) of 10 or more. Please measure regularly.• Do not use alkaline reduction water or beauty water as fish water; changes in pH (pH) will cause fish to die.• Do not use copper containers with weak acid or aluminum containers with weak alkali. The container will be damaged.
 Must comply	<ul style="list-style-type: none">• Please drink in time after alkaline (reduced) water is formed.• When storing a strong acid water container, use a container that is superior to corrosion resistance, such as a glass container, plastic, or ceramic container. Metal containers will corrode when exposed to strong acidic water.• When storing strong acidic water, be sure to store it in an opaque container and use up the stored water within one week.• Metal knives or metal spoons washed with strong acid water or cosmetic water should be wiped clean; if kept wet, it will rust.• When storing alkaline (alkaline) water, be sure to use a closed container and put it in the refrigerator and use it within three days.• When using the new water filter for the first time, please run the unit for more than 15 minutes.• When using the unit every day, please flush it for more than 10 seconds.• When not in use for a few days, please use it for 30 seconds before using it.• Disposal of used filters, please follow the relevant regulations of your region.



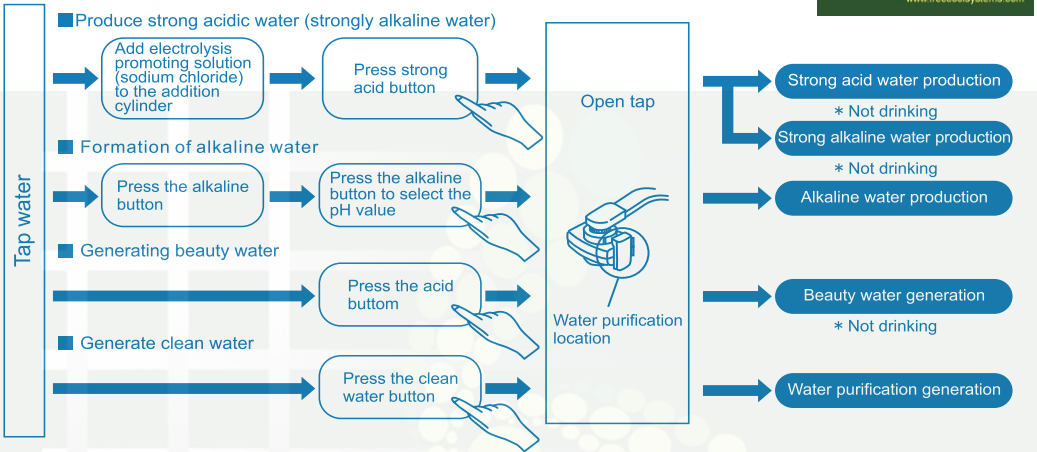

Feature

- This machine has the ability to generate 5 kinds of water: strong acid water, strong alkaline water, alkaline water, beauty water and clean water. One touch button can choose your needs.

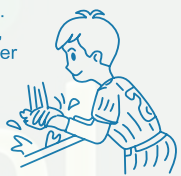

- There are 5 types of water, which are divided into 7 types according to the ph, which can be used for your individual needs.

Generated water species	pH value	Use	Precautions
Alkaline water	H (pH9.5)	Brewing herbal tea or mild herbal tea Most suitable for making barley tea or oolong tea Barley tea can be brewed in half the time of ordinary water.	Do not use medication. When taking medicine, please choose the water purification mode. 
	M (pH9.0)	Brew green tea or coffee and cook rice. This water-made green tea or coffee tastes soft. The rice is soft and plump. Best for your healthy recipes.	
	L (pH8.5)	Keep your health This pH level can be recommended to people who are used to alkaline water.	
Water purifier	pH7.0	Taking medicine or preparing baby milk This neutral water can be used for medicine or daily drinking water.	—
Beauty water	<pH6.0	Skin care When using sensitive water or bath water.	Not suitable for drinking 
Strong acid water	<pH2.7	When using fungicides or washing water. This water-washed kitchen knife, cutting board and utensils can be kept clean. It also kills pathogenic bacteria in fruits.	
Strong Alkaline water	pH11.5	It has the power to decompose the solid sludge. Remove stubborn kitchen mud or clean floors, use strong reduction Additional decontamination power of water. It can also wash fish, meat or vegetables.	

Warning

 Recommended compliance: When making strong acidic water, please ensure that the room is well ventilated and avoid breathing vapor for a long time.

● Annex

Mounting Accessories

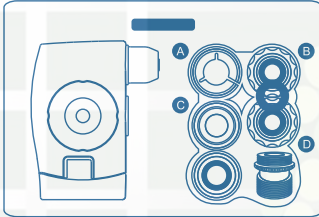

① Adapter



② Suction cup (1 piece)

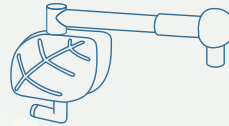

③ Drainage platform (with suction cup)

Use of appliances



④ Electrolytic Promoter



⑤ Funnel



pH test liquid



Test tube

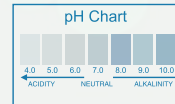

⑥ pH test liquid set

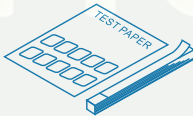

⑦ pH test paper book



⑧ Operating instructions



⑨ Filter replacement label



⑩ Powder filter (CPU-N)



⑪ Cleaning powder

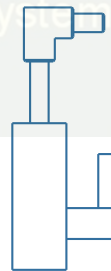

⑫ Faucet

The picture is for reference only, please refer to the actual product.

The name of each part

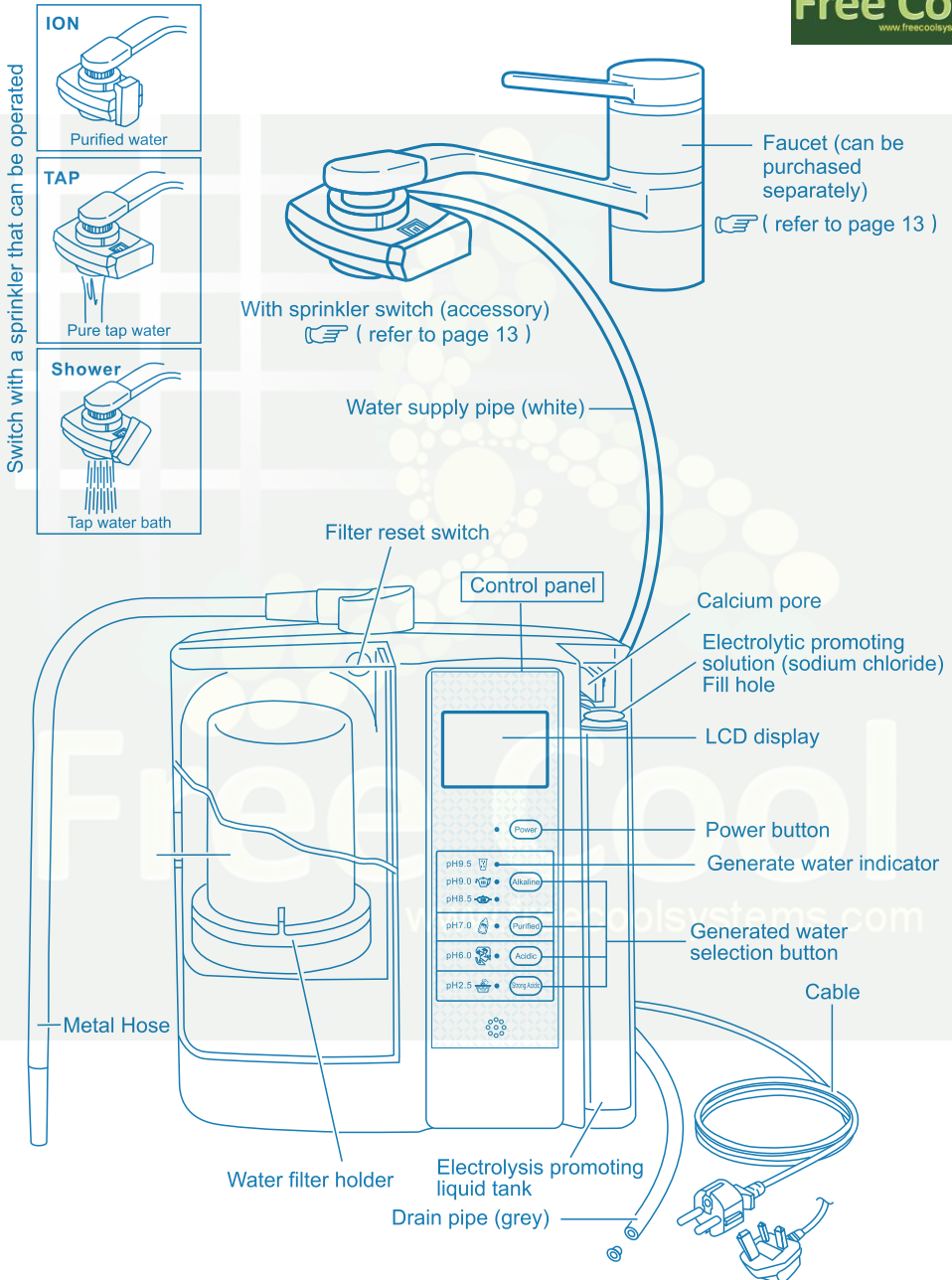

ALWI-551



The name of each part

< Top view >

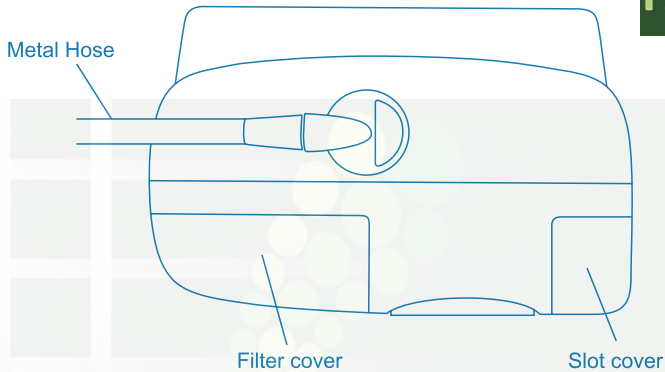

< Bottom view >

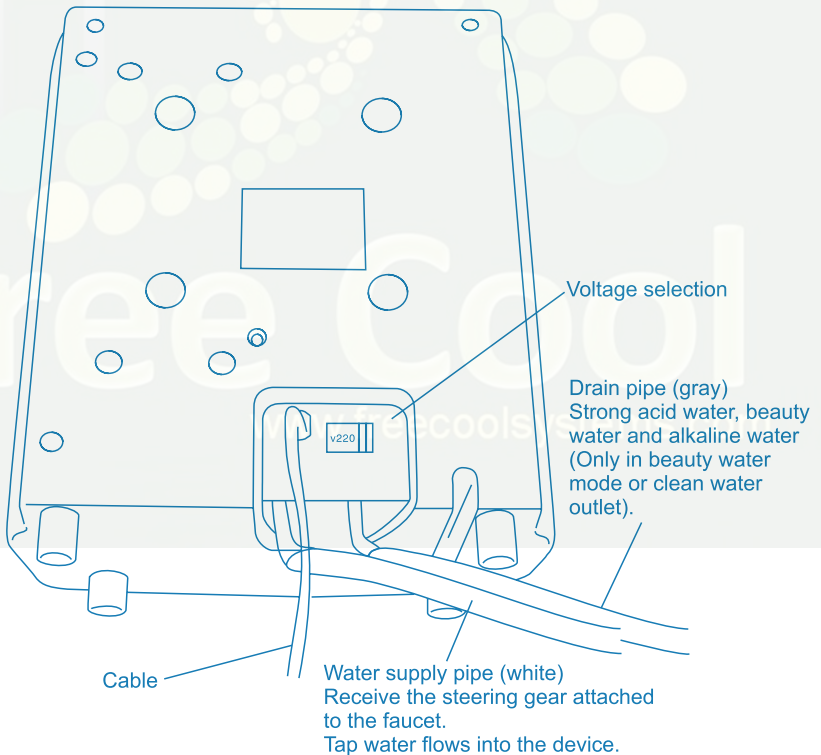

Control panel



Note: This device is shipped with a protective film attached to the operation panel.
Peel off the protective film before use

Control panel protective film

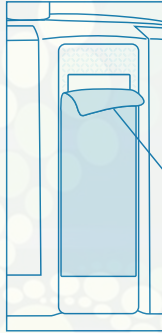
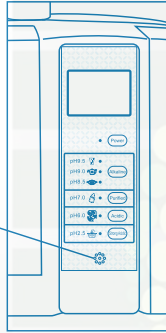

Please peel off this protective film before use.

Operating panel

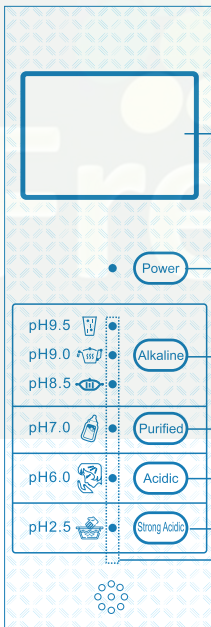

LCD display
Shows the current operating status

Power button / light

Generate water selection button

Generated water indicator



1 Preparation work



■ Selection of location

⚠ Notice



Must comply

- Do not put anything on the device. (May cause a malfunction or problem.)
- Check if the hose is twisted or bent. (May cause water leakage or electrolysis error.)
- Keep the hose below the height of the device. (Otherwise the water in the device cannot be discharged normally.)
- Do not move or move the equipment when there is an electrolytic enhancer in the electrolytic enhancer tank. It will be damaged due to leakage.
- After the equipment is installed, ensure that the height difference between the outlet and the drainage outlet of the outlet hose is 20cm-30cm.

Install this system in accordance with national and local regulations.

● Install according to the following location types

<p>● In a well ventilated area</p>	<p>● Keep away from flammable ● Room temperature should be maintained at 5 to 40°C</p>	<p>● Should be placed in a stable area that can support the weight of the device</p>
<p>● Place the area away from direct sunlight, wind or rain</p>	<p>● No splashing water in the placement area ● Steam, chemicals and dust</p>	

■ Device installation

www.freecoolsystems.com

Set on the kitchen counter

*Note: should be set in a flat place, do not connect to the hot water tap

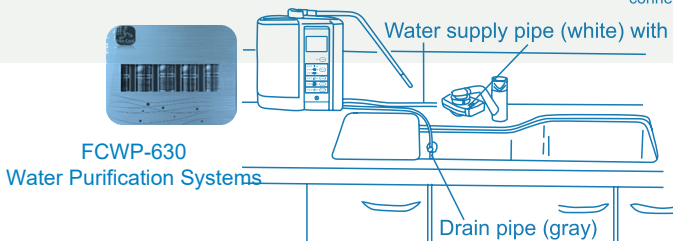

Install switcher

- Some types of faucets cannot be fitted with a switcher. Check the type of faucet before installation. Then install the switch to the faucet as specified.

Do not use a tool to tighten the retaining nut as this may result in damage to the nut.

Fixing nut



Switcher

Adapter

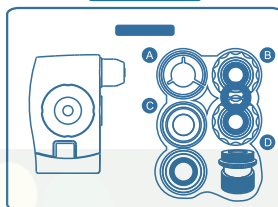

A Kit	16mm	17.5mm	19mm
B Kit			
C Kit			
D Kit			

Round tube with flanged end

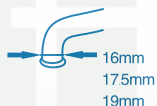

Install an adapter that matches the faucet diameter

< Using an adapter >

A Kit



Fixing nut

Fixing nut



Tighten the fixing nut

Outer bolt type



Save the removed foamer

< Using an adapter >

B Kit

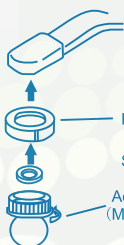

Use coin to tighten adapter B



Tighten the fixing nut

Internal thread type



Save the removed foamer

< Using an adapter >

C Kit

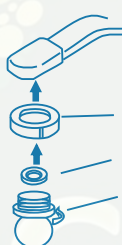

Use coin to tighten adapter C



Tighten the fixing nut

Internal thread type



Save the removed foamer

< Using an adapter >

B Kit + D Kit

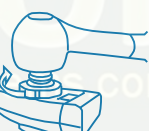
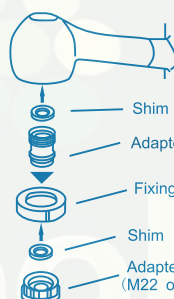

Tighten the fixing nut

If the thread diameter or pitch is not suitable, the thread may be damaged. Thread diameter and pitch should be guaranteed.

<p>Faucet with nozzle</p>	<p>With sensor</p>	<p>Thread diameter does not match</p> <p>The included adapter is not suitable</p> <p>φ 24mm or greater</p>	<p>The nozzle of the faucet is too short</p> <p>19mm or smaller</p> <p>24mm or greater</p>	<p>Square faucet</p>
---------------------------	--------------------	--	--	----------------------

In this case, special faucets should be added or specific switches installed. Please contact your dealer for details.

Installation method 1

Install in order

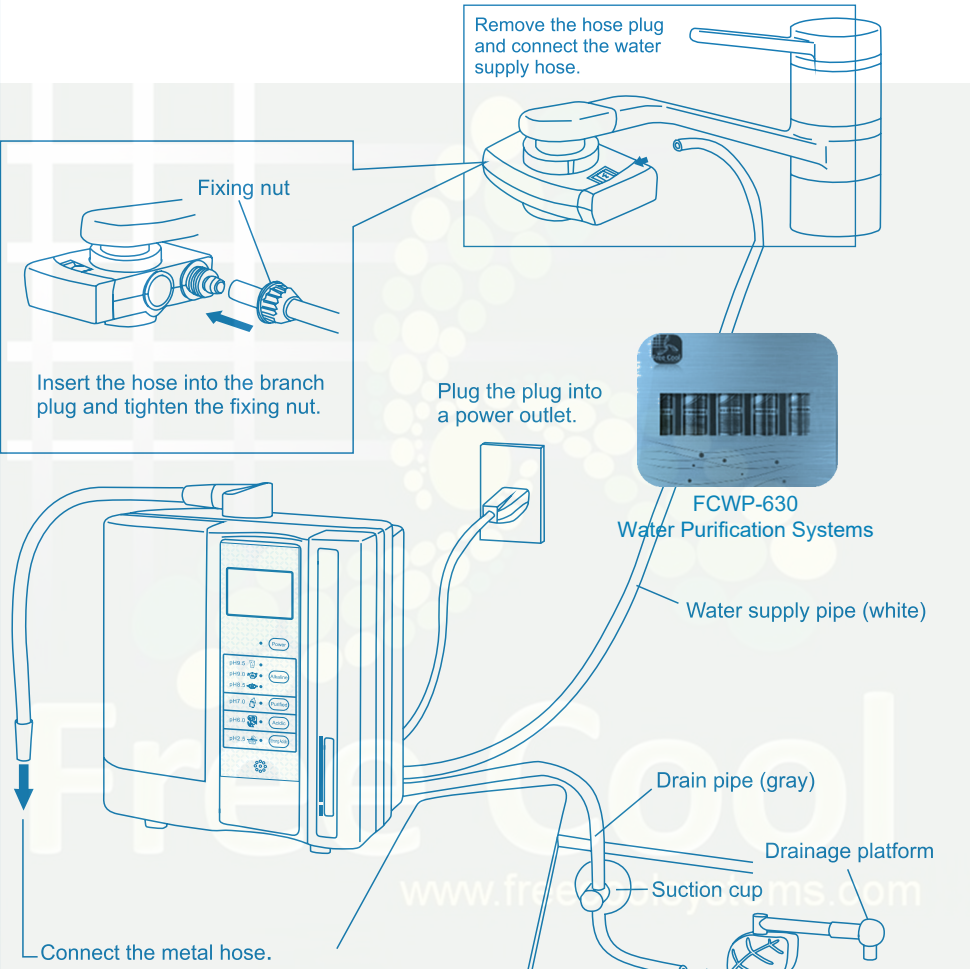

Installation method 2

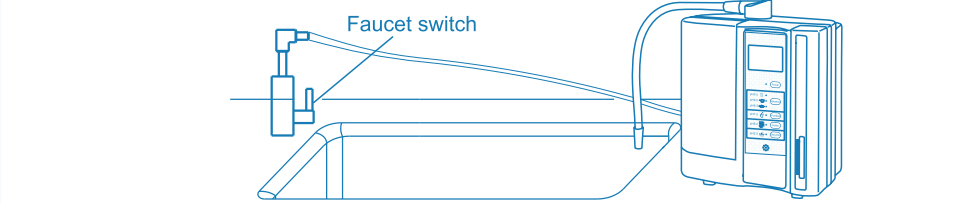

About power line wiring

- Please use the household AC power 220-240V, 50/60Hz socket (Europe / Asia).
- * Using an unsuitable voltage will void the warranty.

Caveat

Prohibited

- Do not bend, stretch, twist, or bundle cables.
- Do not place weights on the cable or get stuck in the cable: this will damage the cable and cause a short circuit and may even cause a fire.
- Do not use loose cables such as damaged or screws to avoid a fire or short circuit.
- Pinning the cable is strictly prohibited. This behavior causes irreparable damage to the cable and may cause a fire.
- Please avoid inserting a large number of plugs into one power outlet.
- Please use normal power / voltage. If an abnormal power supply/voltage is used, it may cause a fire or electric shock.

Notice

Must comply

- Please make sure that the power plug is fully inserted into the socket. Avoid incomplete insertion, resulting in electric shock or heat and fire.
- Before using, please make sure all buttons are working properly.
- The plug must be inserted or unplugged by grasping the plug portion by hand without pulling the wire portion. Pulling the wire can cause damage to the wire
- Fire or electric shock.
- During the storage process, the power cord should be bundled to avoid damage.
- Do not repair the power cable if it is damaged. Please contact your sales office to arrange repairs.



- The wet power plug is prone to electric shock.
If the power plug is heavily wet, then
 - (1) Pull out from the power outlet.
 - (2) Dry the moisture on the plug.
 - (3) Contact the service center (free dialing) for repairs.
- Never touch the power plug with a wet hand. If the plug gets wet, dry the plug after completely disconnecting the power from the outlet.
If you do not execute these programs, you will get an electric shock.
- When the product is not ready to be used for a long time, pull out the plug to cut off the power.
- When cleaning the power outlet, first remove the plug and clean it. Dust on the socket may cause a fire.
- After use, the unit's cable is completely removed from the power supply.

2 Methods of use



■ This product has 4 basic modes and can generate the following 5 kinds of water:

Alkaline water / Beauty water / Strong acid water / Strong alkaline water and Purified water.

■ Basic mode of operation

Water species	Operating panel and faucet operation	Generate water and water intake
<p>① Alkaline water</p> <p>⚠ Note: Can not be used when taking medicine</p>	<p>Open the faucet by pressing the alkaline button. * To switch the pH, first press the alkaline button and select the pH you want (3 gear)</p> <p>pH9.5(H) ③ Press the button pH9.0(M) ② Press the button pH8.5(L) ① Press the button</p> <p>(Repeatedly)</p>	<p>Alkaline water (From the metal hose) (pH8.5~9.5)</p> <p>Beauty water (From the drain) * Not drinking</p>
② Purified water	Press the water button and then open the tap	<p>* When taking medicine, please choose the water purification mode.</p> <p>Purified water (From the water hose) (pH7.0)</p>
<p>③ Beauty water</p> <p>⚠ Note: Not drinking</p>	Press the beauty water button and turn on the tap	<p>Beauty water (From the water hose) (pH5.5~6.5)</p> <p>Alkaline water (From the drain) * Not drinking</p>
<p>④ Strong acid water (* Strongly alkaline water at the same time)</p> <p>⑤ Strong alkaline water</p> <p>⚠ Note: Not drinking</p>	Fill the electrolysis promoting solution (sodium chloride) and press the strong acid button and then open the tap	<p>Strongly acidic water (From the drain) ≤(pH2.7)</p> <p>* Not drinking</p> <p>Strongly alkaline water (From the water hose) (pH10.0)</p> <p>* Not drinking</p>

⚠ Notice

 Prohibited	<ul style="list-style-type: none"> • The method of operation differs depending on the type of water produced. • Be sure to follow the program (see page 18~). • Improper operation or settings can cause malfunctions.
 Must comply	<ul style="list-style-type: none"> • When using this unit or when using a new water purification filter, please use water for 15 minutes or more before using it. • When starting to use it every day, please use water for more than 10 seconds before using it. • When not in use for a few days, please use water for more than 30 seconds before using.



Notice

Volume adjustment

- 1
 - Keep the device "power" button off.
 - Long press "strongly acidic key" for 3 seconds "Tick" and the device enters the volume setting state. The display shows the current volume.

- 2
 - Short press the "Acid" button to increase the volume (range 0-15)
 - Short press the "strong acid" button to decrease the volume (range 0-15)

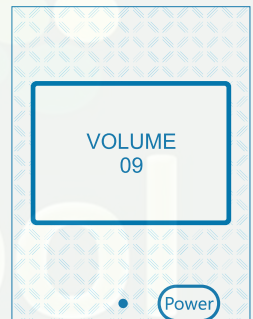

- 3
 - During the setting period, the device will automatically exit without pressing the button within 20 seconds. The mode is set and the current settings are not retained.
 - Press and hold the "Strong Acid" button to save the set value.

Method for producing alkaline water ⚠ Be careful not to use alkaline water when taking medicine

⚠ Notice

- !** Recommended compliance
- When you start using it, drain out the stale water inside the device.
 - When using or replacing the water filter for the first time, rinse the inside of the device for about 15 minutes or more with water.
 - When starting to use it every day, let the water flow for more than 10 seconds.
 - Allow the water to drain for more than 30 seconds when the equipment is not in use for 2-3 days.
 - * The water that started out may be cloudy and light black (This is the activated carbon stream in the water filter core. Come out waiting for clarification before you can use)

1 Press the power button to power up.

- Power light is on

🔊 Button sound

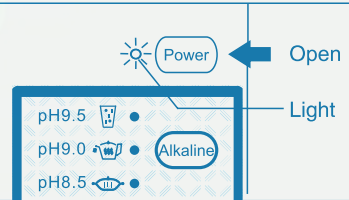

2 Press the alkaline button to select Alkaline water mode and pH (H high, M, L low)

- Press the button to change the 3 gear (H high M Middle, L low) and light up.

🔊 Button sound + Sound guide

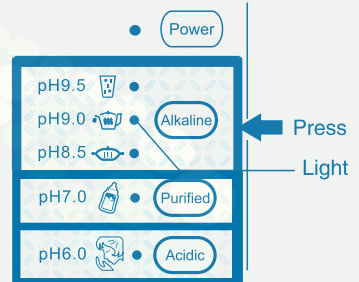

* PH value depending on local tap water quality and water pressure

① Move the faucet lever to the clean water position.

⚠ Notice

- If the water volume (water pressure) is too low, the audible alert and alarm will start to sound and the message will appear on the display.
- * Amplify the amount of water

With sprinkler switch

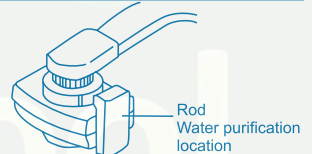

3

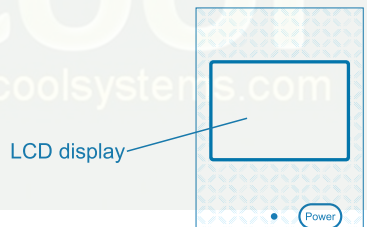

② Produce water out

- The Alkaline water comes out of the outlet hose.
- Acidic water comes out of the drain.

🔊 Sound prompt

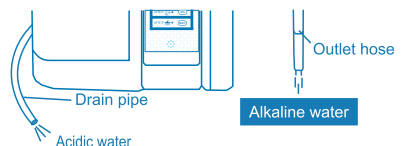

⚠ Attention not drinking

Stop operation

- Turn off the faucet to stop the water from forming. (If you need to continuously generate water, please follow the procedure in step 3.)

⚠ Attention

Adding water for the production of calcium glycerophosphate (method)

- Remove the trough cover and remove the cap of the calcium-filled hole on the upper right side of the fuselage in a clockwise direction, and then add about 2 g of calcium glycerophosphate to the calcium-added cylinder (80% of the calcium cartridge capacity)

- After the calcium cartridge is covered, it is installed in the original position of the fuselage. At this time, please confirm that the butterfly screw handle is fixed in the vertical direction.

Add calcium holes at the top of the fuselage (back)

Add a cover

Add calcium holes at the top of the fuselage (back)

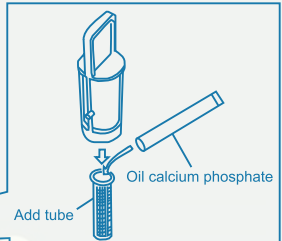
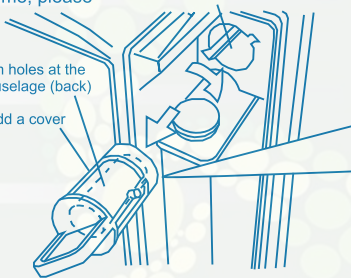

You can buy an optional package containing 12 copies of each three grams (see page 31).

⚠ Attention

- Calcium glycerophosphate increases the calcium concentration in the reducing water.
- This procedure also increases the pH: when adding calcium glycerol phosphate, press the alkaline button to set the appropriate pH level.
- When using calcium glycerophosphate, periodically clean the inside of the calcium cartridge to prevent dissolved calcium from remaining in the cartridge.

Method for measuring the pH of Alkaline water

- Determine the pH of the alkaline water at least once a month using the attached pH test solution

Appropriate pH

Drinkable range.....pH 8.5~9.5

⚠ Notice

- The pH varies depending on the local tap water quality and water pressure.

Complete set of pH reagents



1. To the attached test tube, the alkaline water is about 2cm deep.

- The initial pH of the water is unstable. So please let the water flow for about 10 seconds before sampling.

2. Add 1-2 drops of test reagent to the test tube.



3. The water color in the test tube is compared with the comparison PH value color contrast card to determine the pH value.

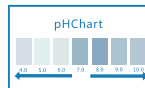

- Do not drink water after pH experiment.
- Please store the test reagent in a cool dark place.
- Keep the test reagent in a place that the baby cannot touch.

The method of generating beauty water. ⚠ Notice That this water is not drinking.

<p>1</p>	<p>Press the power button to power up. • Power light is on.</p> <p> Button sound</p>	<p>Power ← Open Lamp Alkaline</p>
<p>2</p>	<p>Press the acid button. • Acid light</p> <p> Button sound + sound</p>	<p>Purified Acidic ← Press Lamp Strong acid</p>
<p>3</p>	<p>① Move the faucet lever to the Purified water position</p> <p>With sprinkler switch</p> <p>⚠ Notice</p> <p>• If the amount of water (the water pressure is too low), the message appears on the display and sounds and warnings.</p> <p>↓</p> <p>② Generate water to come out.</p> <p>• The beauty water comes out of the metal hose and emits a drip sound during the process of water formation. • The alkaline water is discharged from the drain pipe.</p> <p> Sounds + alarms</p>	<p>Rod Net water level</p> <p>LCD display Power</p> <p>Drainage pipe Metal hose</p> <p>Alkaline Beauty ⚠ Notice Not drinking</p>
<p>4</p>	<p>Method of stopping operation</p> <p>• The process of stopping the water generation can be stopped when the faucet is turned off. (If you need to continue generating, please follow step 3 of the operating procedure).</p>	<p>⚠ Notice</p>

Method for generating strong acidic water/strongly alkaline water

⚠ Notice This water is not drinking

⚠ Warning

- When making strong acidic water, please ensure that the well is well ventilated and avoid breathing vapor for a long time.

⚠ Notice

- When you need to make strong acid water, please add the electrolysis promoting solution to the tank beforehand.
- For the electrolysis promotion liquid, please use the variety specified by our company.
- Please allow water to flow during the cleaning process.

■ Addition method attached to electrolysis promoting liquid.

① Remove the tank cover and remove the cap of the electrolysis promoting liquid addition hole.

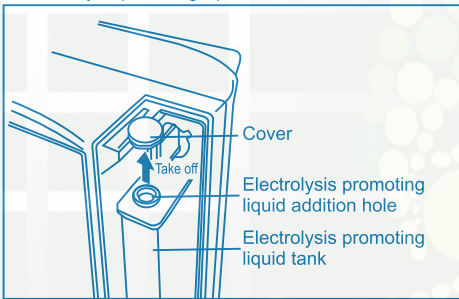

② Put the electrolysis promoting solution into the tank from the addition hole.

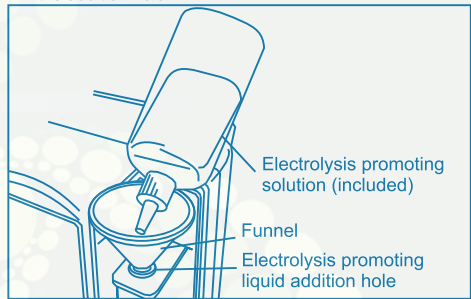

③ The lid of the filling hole is tightly closed.

⚠ Notice

- When the strong acid water is generated for 10 seconds and then changed to other gears, it will automatically enter the washing standby state; it will be automatically washed for about 30 seconds.
- Please wash the electrolyte promotion tank in time.

< Electrolysis promoting liquid tank cleaning method >

① Take of the tank cover and remove the entire tank of the electrolysis-promoting liquid tank.

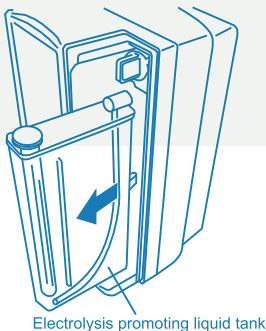

② Take of the lid of the electrolysis-promoting liquid tank and wash the tank.

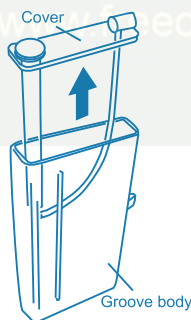

③ Install the tank to the original position by installing the electrolysis accelerating tank.

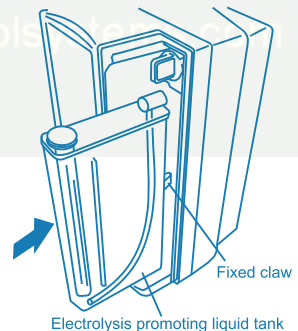

1

Press the power button to power up.

- Power light is on

 Button sound

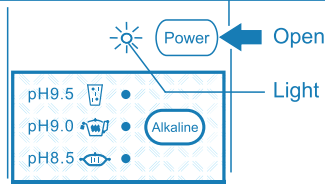

2

Press the strong acid button.

- Strong acid light

 Button sound + sound

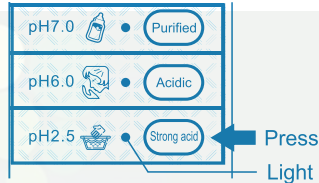

① Move the tap control rod to the net water level.

Notice

- If the water pressure is too low, the display will show up and the sound will be heard. Increase water flow.
- When you first use the electrolyte in the cell, please notice that it takes about 20 seconds for the electrolyte to flow into the cell. At this time, LCD showed "lack of promoter fluid". It takes about 20 seconds for the machine to return to normal.
- When strong acidic water is produced, the amount of water will be reduced if the message of "lack of promotion liquid" is not extinguished for more than 30 seconds.

Nozzle switcher

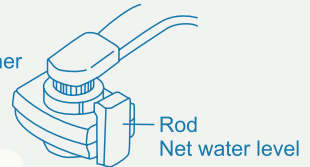

3

② Produce water to drain

- Strong acid water is discharged from the drain pipe and the sound of water dripping during the generation process is always ringing.
- Strongly alkaline water comes out of the outlet hose.

 Sounds + alarms

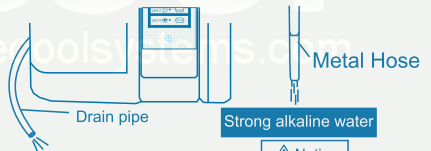
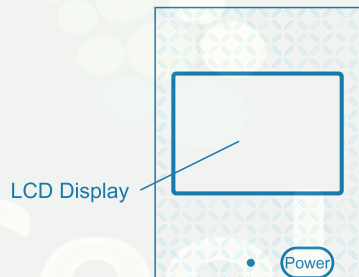

Strong acid water

 Notice
Not drinking

Strong alkaline water

 Notice
Not drinking

Notice

- When the electrolysis promoting liquid is missing, the sound will sound and the alarm will beep and the message will be displayed on the LCD. Please fill the electrolysis promoting liquid.
- After the strong acidic water/strongly reduced water is generated, the device will automatically enter the 30-second cleaning mode after switching to other modes.

4



Method of stopping operation

- Turn off the tap to stop the water generation process. (If you need to continue generating, follow step 3 of the procedure.)

Test Method for PH Value of Strong Acidic Water

- Test paper with pH value (attached)

■ Method of using pH test paper.







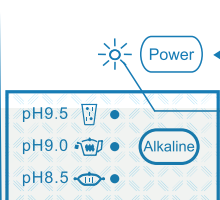

1	Careful diffuse pH test paper in sampling water (half a second). Then take it out right away.	
2	Shake the test paper gently to remove excess water.	
3	Check by comparing the wetting part of the paper with the color of the standard colorimeter The comparison and determination of colours should be carried out in places with bright lights.	

 Notice

Must comply

- The comparison and determination of colours should be carried out in places with bright lights.
- The pH test paper can only be used to determine the pH value of strongly acidic water.
- Do not lick the pH test paper with your tongue. In case of licking the test paper, rinse the mouth immediately and rinse it.
- Pigments dissolve in sampled water for too long (more than 0.5 seconds) and the results are not correct.
- If the pH test paper is kept in the air for too long, the correct data may not be obtained.
- Sampled water should be kept at room temperature so that pigments do not dissolve quickly into the water.
- The appearance of the pH test paper varies depending on the storage conditions. Appearance differences do not necessarily affect experimental performance.
- Store the pH test paper in a cool, dry place.

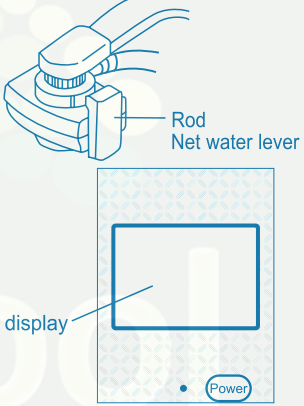
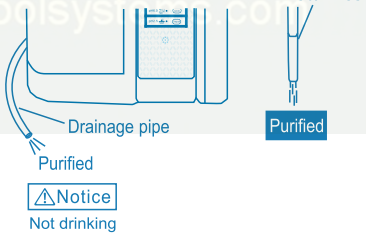
 Notic

1	<p>Press the power button to power up</p> <ul style="list-style-type: none"> · Power lamp on  Button sound	 <p>Power ← Open</p> <p>Lamp</p> <p>pH9.5</p> <p>pH9.0</p> <p>pH8.5</p> <p>Alkaline</p>
2	<p>Press the Purified water button</p> <ul style="list-style-type: none"> · Purified water lamp on  Button sound + sound	 <p>Purified ← Press</p> <p>Lamp</p> <p>pH7.0</p> <p>pH6.0</p> <p>pH2.5</p> <p>Purified</p> <p>Acidic</p> <p>Strong Acid</p>
3	<p>① Move the tap control rod to the net water level</p>  <p>② Produce water out</p> <ul style="list-style-type: none"> · The purified water comes out of the water hose. * Do not use the purified water from the drain.  Sound <p> Notic</p> <ul style="list-style-type: none"> · Please use the purified water from the metal hose. · When you start using it, drain out the stale water inside the device. · When using or replacing the water filter for the first time, rinse the inside of the device for more than 15 minutes. · When starting to use it every day, let the water flow for more than 10 seconds. · Allow the water to drain for more than 30 seconds when the equipment is not used for 2-3 days. * The water that started out may be cloudy and light black. (This is the flow of activated carbon from the water filter, which can be used after waiting for clarity.) 	 <p>Switcher with sprinkler</p> <p>Rod</p> <p>Net water lever</p> <p>LCD display</p> <p>Power</p>  <p>Metal hose</p> <p>Drainage pipe</p> <p>Purified</p> <p> Notic Not drinking</p>
4	<p>Method of stopping operation</p> <ul style="list-style-type: none"> · The process of stopping the water generation can be stopped when the faucet is turned off. (If you need to continue generating, please follow step 3 of the operating procedure). 	

Automatic cleaning

- Do not drink water from the automatic cleaning program.
- Allow water to drain freely during the cleaning process.

The deposition on the electrodes in the cell may reduce the water quality.
The device automatically cleans the electrolytic cell.

< In the wash >



Sounds + alarms

< The water is flowing >

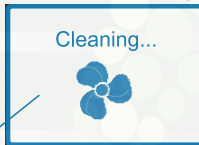

LCD display

- When the device water meter flow reaches the wash flow setting value,
- Inform you that an automatic cleaning procedure will be performed.
- When the work starts, the cleaning work starts about 30 seconds automatically.

⚠ Notice

When the device is working, it will not be converted to the automatic wash mode, and the device will perform automatic cleaning when it is next working.

< Tell you the message that the device is in the cleaning >



Sound

< Standby mode >

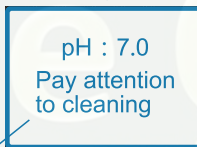

LCD display

- At the beginning of the next work, if you need to wash, the device sends a notification on the left.
The total flow and cleaning reminder are displayed alternately below the display.

The device automatically cleans in the following cases:

- ① After the equipment water flow rate is greater than the set cleaning flow rate.
- ② Generate strong acid water for 10 seconds and then switch to other gears.

3 Replacement filter

⚠ Notice

- The filter cartridge is a standard accessory that comes with the newly purchased device.
(Replacement services for activated carbon filter cartridges are also available. Please contact your sales office)

This device is self-notifying on the LCD screen on the sound prompt, alarm and control panel when the water supply is stopped during the replacement period.

- When the filter needs to be replaced



Sound +

LCD

LCD display

LCD display

⚠ Notice

- "Filter expires" when the prompt appears on the LCD display.
- Please replace the filter after stopping the water.

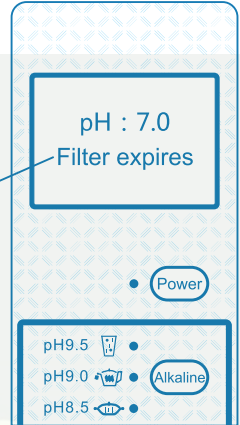

Push the hook of the filter cover on the left side of the fuselage to remove the cover.

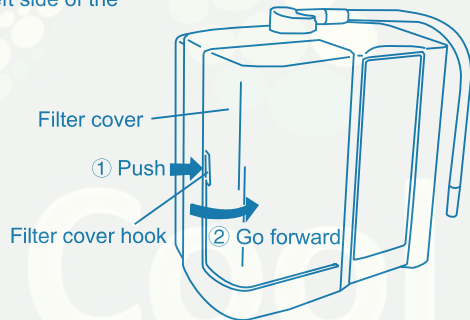

You can unlock the gripper of the filter holder by turning it 40 degrees counterclockwise. Lift the filter to remove it.

⚠ Notice

- Please notice that the water in the filter will leak out when the filter element is removed.

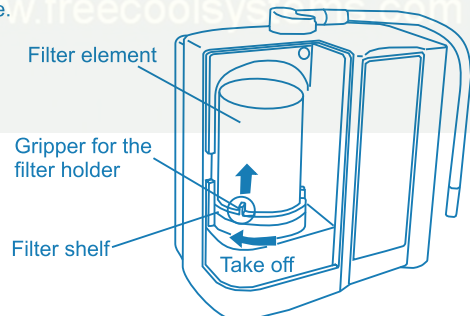

Make sure that the old seal is not left in the fuselage and confirm the installation position, then tighten the filter. Turn the filter holder 40 degrees counterclockwise and lock it.

3

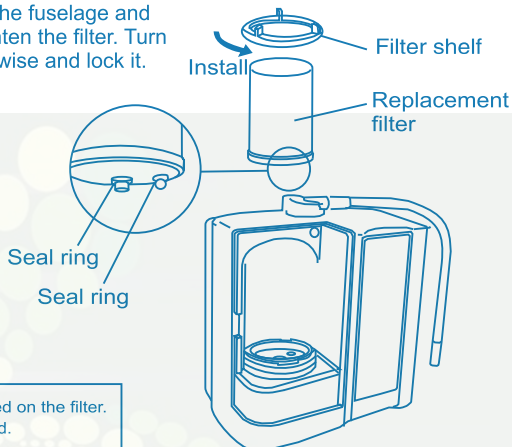

 Notice

- Please confirm whether the two seals are fixed on the filter.
- Please confirm that the filter holder is installed.

Press the filter reset switch for 5 seconds.
Sounds up "Filter has been reset".

4

 Sounds and sounds + alarms



Install the filter cover

Filter reset switch

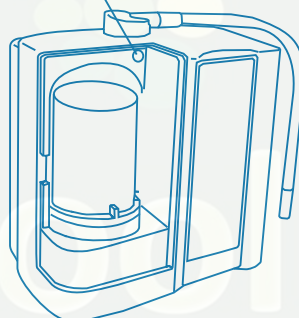







 Notice

- Confirm that the filter used is original. (Do not use filter cartridges from other manufacturers. It can cause malfunctions and other problems.)
- When you use the device for the first time or replace the filter element, give it water for more than 15 minutes.
- Used filter elements (combustible materials) should be disposed of in accordance with your local environmental regulations.

4 Safety instructions

■ To avoid injury or accident, please observe the following:

 Warning	
 Forbid	<ul style="list-style-type: none"> ● Personnel with the following conditions shall obtain the approval of a doctor or pharmacist before drinking the alkaline water generated by the equipment. ● Please observe the following precautions before drinking the alkaline water. <ul style="list-style-type: none"> • Do not take medicine with alkaline water. • If you have any questions about your health, please consult your doctor or pharmacist. ● Use only water treated by the municipality, such as tap water, when drinking. <ul style="list-style-type: none"> • According to the water quality equipment in different places, the chlorine removal rate and pH value may change.
	<ul style="list-style-type: none"> ● When children and the elderly use the device, please pay attention to supervision. ● Children who use this device must be over 8 years old and have reduced physical, functional or mental abilities or lack of experience and knowledge. The equipment should be used in a safe manner under supervision or guidance and should be aware of the hazards involved. Children are not allowed to play with this device. Children are not allowed to clean and maintain without supervision.
	<p>Failure to observe the following warnings may result in electric shock, fire or accident, as well as serious personal injury and property damage.</p> <ul style="list-style-type: none"> ● Do not spill water or oil on the main body of the device. ● Do not use a damaged power cord to operate the device. ● Do not mess or try to repair the device.

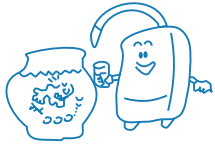
 Notcie		
 Must comply	<ul style="list-style-type: none"> ● Do not splash water or oil on the body. It can cause fire or electric shock. 	<ul style="list-style-type: none"> ● When the position of the drain pipe is higher than the fuselage, do not use this device. In this way, water cannot come out of the fuselage and cause a malfunction. 
	<ul style="list-style-type: none"> ● Do not set the device next to the heating element or in corrosive gases. In this way, it may be damaged or cause the equipment to bend or deform. 	<ul style="list-style-type: none"> ● Do not use this water to feed fish or feed small animals. Changes in pH can cause discomfort or even death in animals. 

⚠ Notice

- Rabbit direct sunlight.
It can cause the device to bend or deform.



- Do not use thinner or volatile oil when cleaning
Any detergent that polishes powder or chlorine
It will damage the device.



- Do not put anything on the device.
One will damage the fuselage or something falling.



- Please use salt water or water that is too hard.
It can damage equipment or shorten its service life.

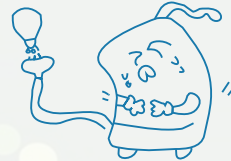

Must comply !

- If you want to move the device, please remove the electrolysis promotion tank first.
Electrolytic ionization promotes fluid leakage and can cause malfunctions.



- Do not put hot water in the device (above 40 °C)
It can cause damage or cause malfunction.



- Do not operate the device with damaged wires.
It can cause fire, electric shock or malfunction.



- Avoid using frozen water when using this device in cold areas.
(If you do not use the device for a long time, please take off the filter element and store it separately from the body. Please be careful not to touch the replacement switch.)
Failure to comply with the above may result in water leakage or mishandling.

- Do not call this device or attempt to repair it.
Avoid fire, electric shock or accidents.



⚠ Notice *Groundwater containing free carbon reacts to pH test solution

- When using ground water or well water without using tap water, depending on the amount of free carbonic acid in the water, the pH of the reduced water may sometimes return to near neutral after the electrolysis (after 1 to 2 seconds) (pH test reagent change from blue to green). Despite this, reduced water still has many characteristics, delicious and healthy.
- Test method: 3~4 drops of test solution were dropped into an empty transparent cup. Reduced water (pH 9.5) was placed in the cup.
- Reaction: After the reduced water is placed in the test solution, the blue-violet color changes to → blue. After 1 to 2 seconds, the blue color changes to → green.

Cleaning method

Cleaning powder filter (CPU-N)
Please replace the cleaning powder filter



Cleaning powder



Notice Use cleaning powder once a week or every two weeks.

- Make sure to turn off the tap and stop running.
- Turn off the power switch and pull the cord out of the socket when cleaning.
- For cleaning powder, please use our company's product package as a washing amount.
- Using other company's products may damage the machine.



The cleaning powder contains citric acid, so please avoid using the water used for washing.

- ① Unscrew the cleaning filter bottom cover, pour the cleaning powder evenly into the filter element, and then reinstall the cover. Note that the O-ring cannot be displaced or pulled out.



- ② First close the faucet, remove the filter cover of the fuselage and screw the shelf to remove the filter.



- ③ After installing the cleaning powder unit on the fuselage, fix it with a shelf.

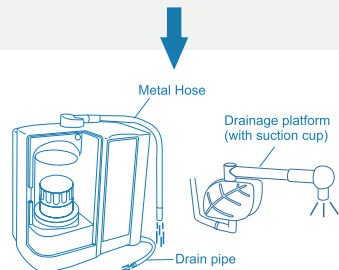

- ④ Place the top of the metal hose and the drain of the drain/drain platform at the bottom of the cup, let the water flow through the tube until the water in the cup is half full, close the faucet, place the tube and hose in the cup three to five After three hours, take out the cup, open the faucet, and let the water flow for a few minutes.

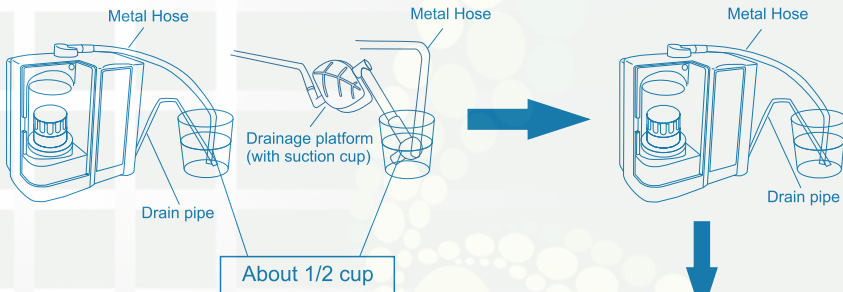

⚠ Make sure the cup does not fall over

- ⑤ Close the faucet. Remove the filter element from step ① and let it pass for a few minutes.

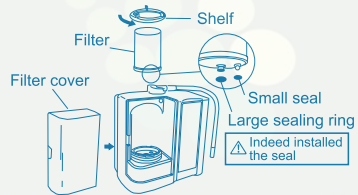

Washing machine

Please use "cleaning powder" every one to two weeks.

Deep cleaning is recommended once a year by the regular service center. The deep cleaning interval depends on the water source. It is recommended to use a water softener for water sources with very high hardness.

www.freecoolsystems.com

6 Option

• Option



① Replace water filter activated carbon type



② Electrolysis promoting solution

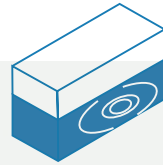

③ Calcium glycerate powder (24 packs, 20 g each)



④ Water supply pipe 1-5mm

⑤ Water supply pipe 1-5mm

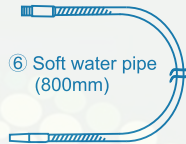

⑥ Soft water pipe (800mm)



⑦ Pre-filter



⑧ DPS replacement filter



⑨ This sub-pH pH test paper



⑩ pH test liquid



⑪ Test tub

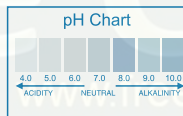

⑫ pH and chlorine content test comparison card



⑬ E-CLEAER N
Cleaning powder filter
Cleaning powder (24 packs)

ph value test liquid set



⑭ Cleaning powder (24 packs)



⑮ Chlorine reagent (15ml)
(Residual chlorine determination reagent)
limited to the United States

The picture is for reference only, please refer to the actual product.

ALWI-773

Name	Ionizer Water	Model	ALWI-551
Unit Size	270×170×340(mm)	Package dimensions	325×255×475(mm)
Input voltage	AC110V~220V	Rated power	220W
Water flow rate	2~4L/min	Work pressure	0.2~0.3MPa
Net weight	3.6Kg	Gross weight	4.4Kg
Water source temperature	5~40°C	Electrode material	Platinum titanium alloy electrolytic plate
Electrolysis method	Continuous pulse DC electrolysis	Water quality	Qualified municipal tap water

www.freecoolsystems.com

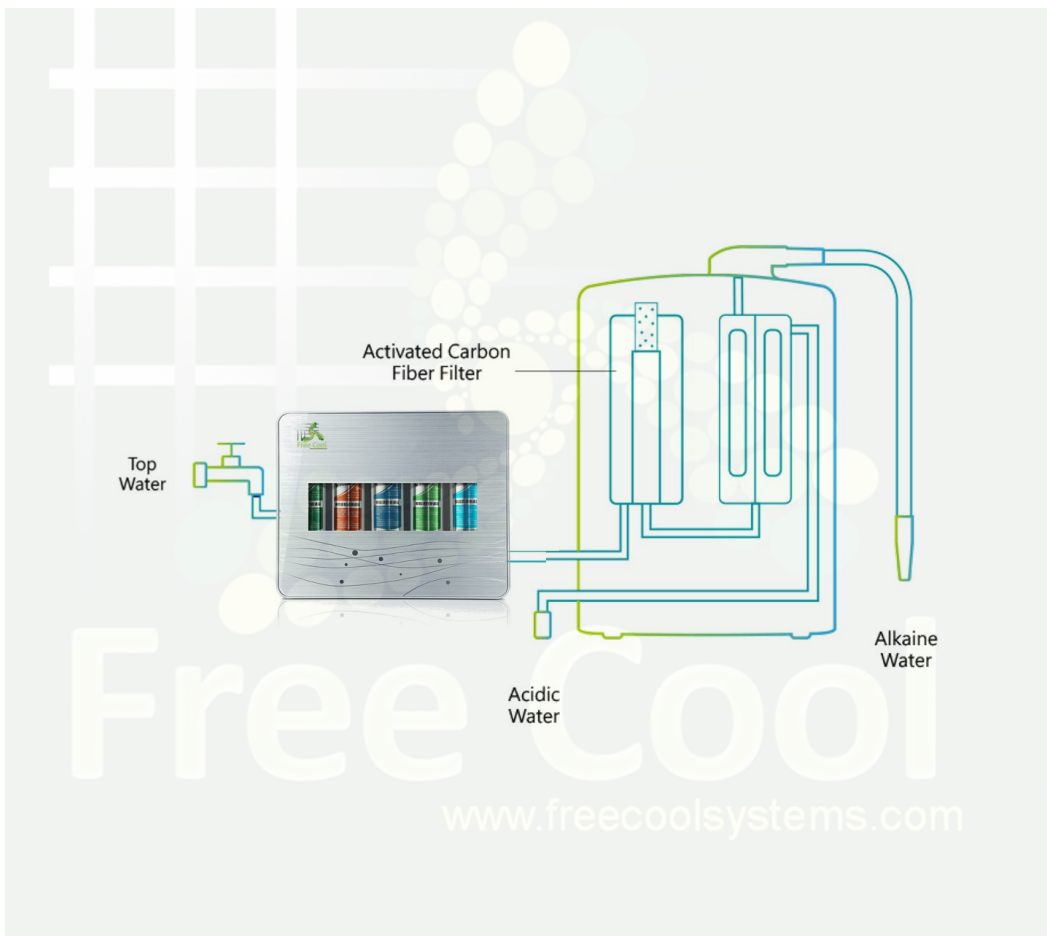



Alkaline Ionized Water

- Has a **pH of 8.5 – 10.0** to neutralize acidity found in the body
- Has **smaller water molecule** clusters for faster hydration and cell permeation
- Has a **negative ORP** (oxidation reduction potential -100 to -500mV) creating **anti-oxidant** effect which seeks out and neutralizes free radicals



Multitasking Corporation Ltd

Multitasking Inductor Electronic LTD

647, Yeogsam-Dong, Gangnam-gu, Seoul, Korea,
289 Dagang san Road Beilun District Ningbo Zhejiang ,China. Email:
info@freecoolsystems.com ,www.freecoolsystems.com

